

# Business Unit Standards

TLA / Road Transport / Dispatch

## Chocking and strapping vehicles

Chock and strap the vehicle in accordance with the examples shown below.

Vehicle on the peak

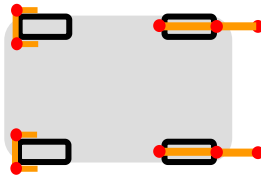

⇒2 chocks on the front axle

⇒2 chocks on the rear axle

Flat-loaded vehicle

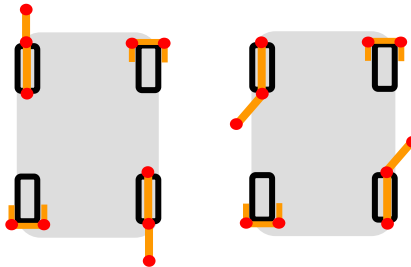

⇒2 chocks

⇒2 straps positioned diagonally.

Where it is not possible to place chocks / straps diagonally, place the 2 chocks and 2 straps wherever possible but in a safe position.

1

Stacked vehicle

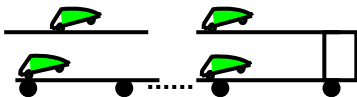

For a vehicle stacked on:

Manual ramp

⇒1 strap on each "upper" axle wheel and one chock on each "lower" axle wheel.

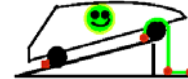
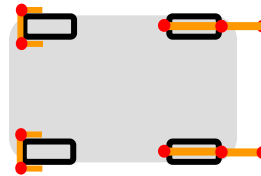

The strap is wrapped around the tyre and is attached to a fixed part of the truck or trailer.

Mechanical or hydraulic ramp

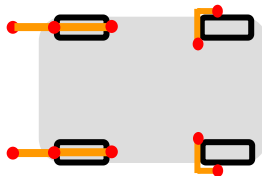

⇒1 bevelled chock inside each wheel on the upper axle

⇒2 straps on the lower axle

2



Make sure that each wheel is tied.

# Business Unit Standards

TLA / Road Transport / Dispatch

## Chocking and strapping vehicles

3

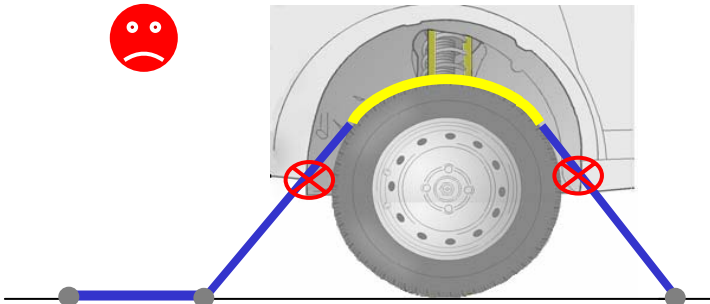

Position the chocks and straps in such a way that they do not come into contact with any part of the bodywork.

4

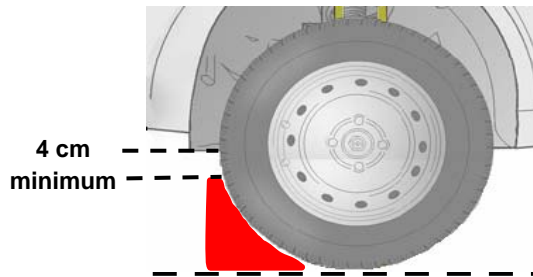

Place chocks in a perpendicular position and in contact with the tyre.

Ensure that there is a minimum clearance of 4 cm between the vehicle structure and the chock.

2 types of chock:

- Standard chocks with 2 anchor points and locks in the same place.
- Bevelled chocks with 1 anchor point and 1 locking point.

5

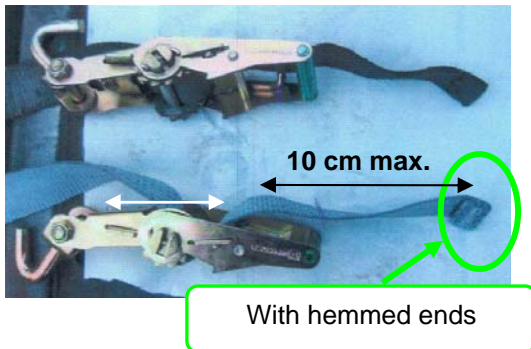

Straps with hemmed ends:

- Placed on nearside vehicles.
- Maximum of 10 cm between the hemmed ends and the 3<sup>rd</sup> anchor point in case of emergency stops.



# Business Unit Standards

TLA / Road Transport / Dispatch

## Chocking and strapping vehicles

Position the straps, in the tyre centreline, attaching them to the deck by 3 anchor points.

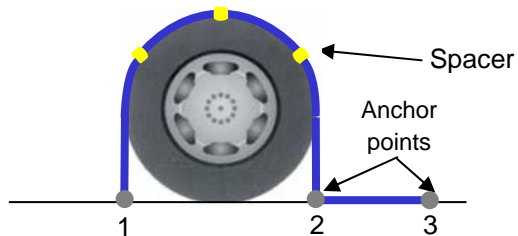

**Straps with spacers:**

- ☛ The 3 spacers at 10 and 2

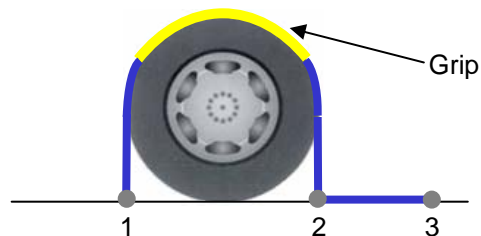

**Straps with slip-resistant grips:**

- ☛ The grip is centred and in contact with the top of the tyre (at 10 and 2)

6